

▼ Gamesa Energy USA

One South Broad Street, 20th Floor
Philadelphia, PA 19107 (USA)
Tel. 215 665 9810 – Fax. 215 665 9811

December 21, 2006

Dennis Mash, Manager
Windber Area Authority
1700 Stockholm Ave
Windber, PA 15963

Dear Dennis,

Enclosed please find several documents on the construction of our Shaffer Mountain Wind Farm. The first document that you will find is a map of our project area. This shows the planned locations of turbines, roads and cables. The width of the green area depicts the relative width of clearing (60 feet) that needs to be done for the roads and additional area around the turbines. The parcel boundaries drawn on this map are approximate and based on deed plots and tax assessment maps. As you can see, we designed the project to have minimal impact to streams in the area. We have one stream crossing planned over Piney Run along Easy Camp Rd. This will be done with an overhead cable. All other cables within the project will be buried.

The next item that you will find is the Access Roads design sheet. In most cases, the roads within the project will be constructed per the top left design since our cables will follow along our roads. Once construction activities are completed everything will be graded and reseeded except for the 15 ft wide gravel road. The only exception to this design is when we link turbines C31 and B21. This section will contain an underground trench and the overhead stream crossing mentioned above. The underground cable specifications are depicted on the Trench sheet. Cables will be buried at a depth of 44 inches.

The Crane Pad design sheet shows what the area around the turbines will look like. We need a 100' by 130' level gravel pad to assemble the blades and support the crane. This will be located adjacent to a 60' by 60' foundation area. The design of the foundation follows on the next sheets. This is the foundation being used on our Allegheny Ridge project. The foundation will be buried to a depth of 8 feet below grade and will be approximately 50' across. The actual width of the foundations for this project will be determined following detailed bore tests. The Clearing sheet specifies the area around the turbines that must be cleared. As depicted, we only clear enough room to assemble the rotor (i.e. hub and blades).

We will not be using any chemicals to control vegetation in our construction activities. I also want to let you know that volume of fluids within the turbine is 148 gallons. It should be noted that most residential heating oil tanks have a capacity of 250 gallons. This includes 100 gallons of gear box oil and 48 gallons of hydraulic oil. The design of the nacelle, which houses the generator and supports the rotor, and tower are such that they will contain any spills or leaks that may occur. Gamesa also uses air cooled transformers within the turbines instead of oil cooled transformers to help prevent

the risk of leaks. A spill control plan will be developed to address spill concerns prior to commencement of construction.

I look forward to meeting you on January 4th to discuss our project. I hope that by touring our Allegheny Ridge Wind Farm near Portage you will find that Gamesa is concerned about protecting the environment and that we do things appropriately. Please contact me if you have any questions about the information contained herein.

Regards,



Tim Vought
Project Developer

Cc: Hank Shaak, Berwind Natural Resources Corporation

CRANE ROAD & CABLE TRENCH

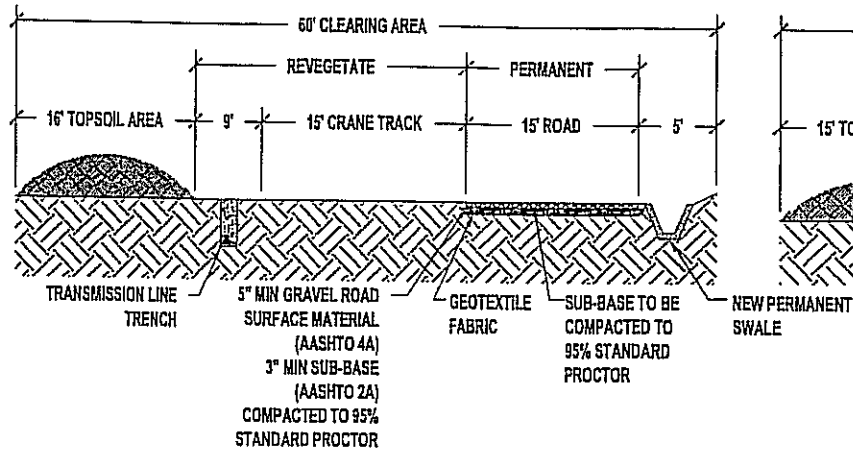

CRANE ROAD

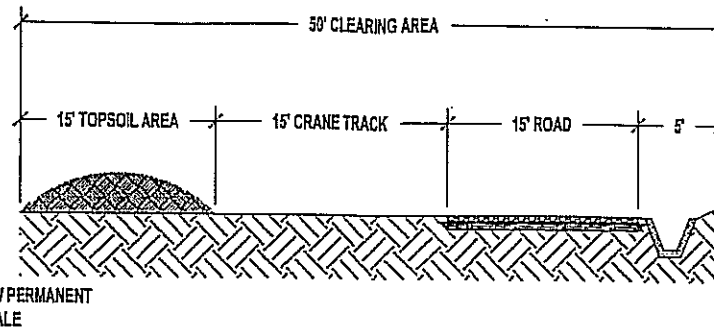

NOTES:

1. THE CRANE ROAD SECTION APPLIES TO ALL NEW ROADS AND EXISTING ROAD IMPROVEMENTS BETWEEN TOWERS, AS SHOWN IN THE EROSION CONTROL PLANS.
2. REVEGETATION AREAS SHALL BE RIPPED AND RE-SEEDING PER SPECIFICATIONS IN THE EROSION CONTROL PLANS.
3. INSTALL NEW SWALE PER DETAIL IN THE EROSION CONTROL PLANS SWALE LOCATION SHEET EC3 ONLY AT LOCATIONS SHOWN ON THE LAYOUT PLANS.
4. ACCESS ROADS (15' WIDE) APPLIES ONLY TO AREAS BETWEEN WIND TOWERS. ACCESS ROAD IMPROVEMENTS SHALL BE 15' WIDE. CRANE SHALL BE ASSEMBLED ON TOP OF PROJECT SITE AND USED BETWEEN WIND TOWERS. FOLLOWING WIND TOWER CONSTRUCTION, DISASSEMBLE CRANE TO REMOVE FROM SITE.
5. ACCESS ROADS (15' WIDE) WILL BE PLACED ON EITHER SIDE OF THE 30' ROADWAY ACCORDING TO THE DETAILED CIVIL LAYOUT DRAWINGS TYP-2100.
6. CABLE TRENCHES WILL BE PLACED ON EITHER SIDE OF THE ROADWAY ACCORDING TO THE DETAILED COLLECTION SYSTEM DRAWINGS TYP-3100. THE TRENCH AREA (9' WIDE) MUST BE GRADED WITH THE ROADWAY.
7. TOPSOIL SHALL BE STOCKPILED IN THE SPECIFIED AREA ALONG THE SIDE OF THE ROAD AND MUST BE RE-DISTRIBUTED AND RE-SEEDING ALONG THE CRANE TRACK AND CABLE TRENCH AT THE END OF CONSTRUCTION.
8. THE OWNER MAY REJECT OR CHOOSE TO CHANGE ROAD MATERIAL AT ANY TIME.
9. SUB-BASE MATERIAL MUST BE DRY AND COMPACTED TO 95% STANDARD PROCTOR BEFORE PLACING THE GEOTEXTILE FABRIC AND GRAVEL.

TYPICAL ROAD & CABLE TRENCH

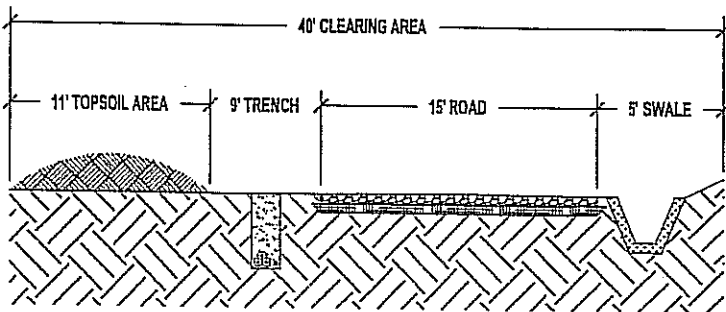

TYPICAL ROAD

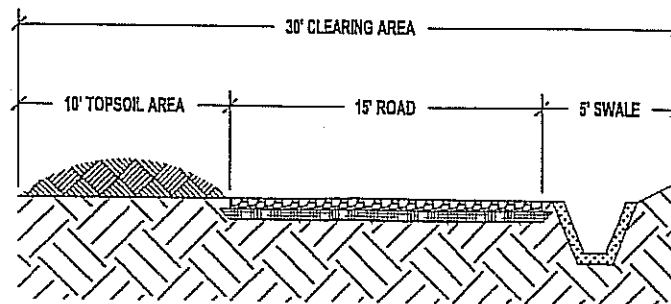

TYPICAL TRENCH

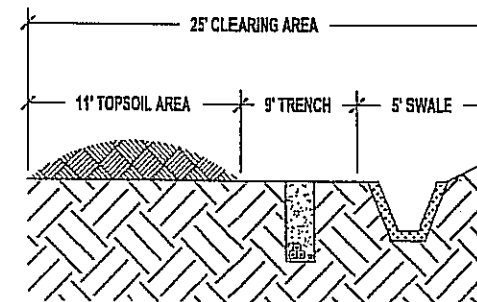

TYPICAL WIND FARM
ACCESS ROAD DIMENSIONS

REV	DATE	DESCRIPTION	DESIGNED BY	CHECKED BY	APPROVED BY	SCALE: NOT TO SCALE
1	8/20/08	ISSUE DIMENSIONS AND DIMENSIONS FOR ALL ACCESS ROAD TYPES	FA	FA	J	
2	11/2/08	REVISED	FA	FA	J	

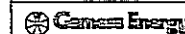

DWG. NO.
TYP-5001

TYPICAL WIND FARM

TRENCH

**CABLE TRENCH
(1 CIRCUIT)**

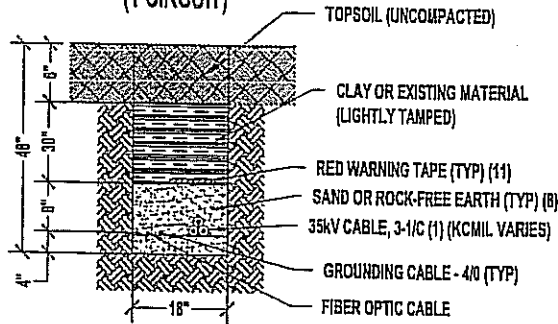

**CABLE TRENCH
(2 CIRCUITS)**

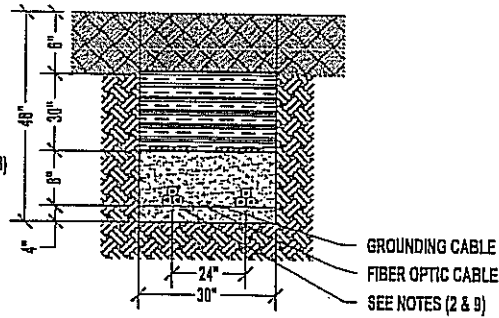

**CABLE TRENCH
(3 CIRCUITS)**

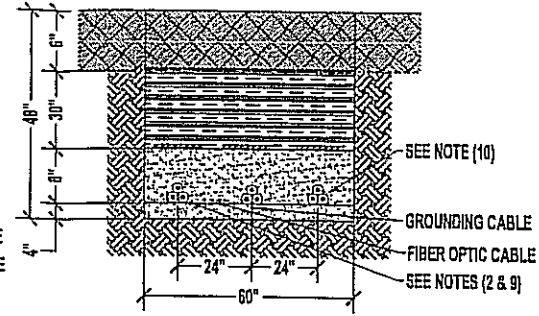

**CABLE TRENCH
(4 CIRCUITS)**

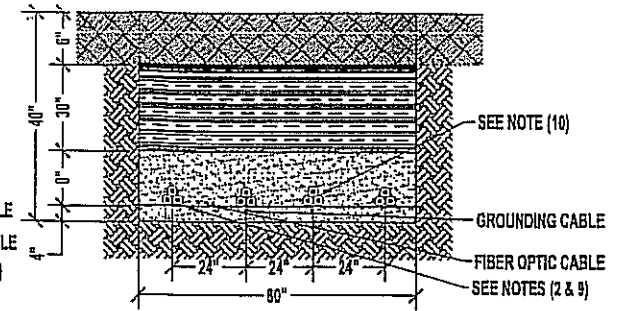

**CABLE TRENCH FOR
ACCESS ROAD CROSSING
(1 CIRCUIT)**

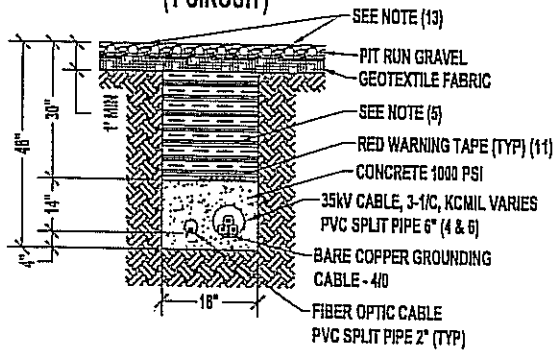

**CABLE TRENCH FOR
ACCESS ROAD CROSSING
(2 CIRCUITS)**

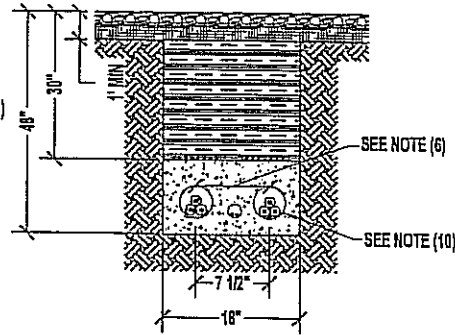

**CABLE TRENCH FOR
ACCESS ROAD CROSSING
(3 CIRCUITS)**

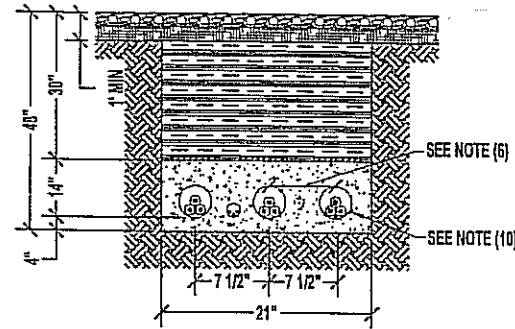

**CABLE TRENCH FOR
ACCESS ROAD CROSSING
(4 CIRCUITS)**

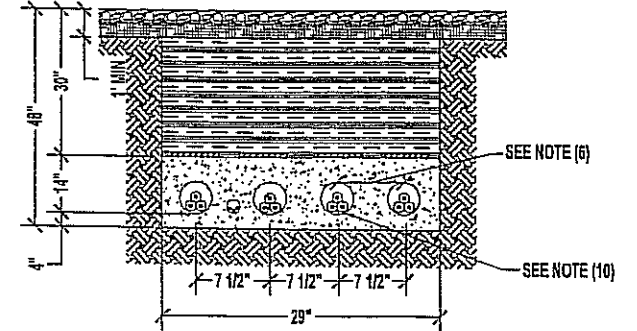

NOTES:

1. ALL CABLES MUST BE BURIED AT A DEPTH OF AT LEAST 36" (NESC 353)
2. WHEN TWO OR MORE CIRCUITS ARE OCCUPYING THE SAME TRENCH, NOT UNDER A ROADWAY, THE CIRCUITS MUST BE SEPARATED BY AT LEAST 24" (NEC 310.60)
3. WHEN TWO OR MORE CIRCUITS ARE OCCUPYING THE SAME TRENCH UNDER A ROADWAY, THE CIRCUITS MUST BE SEPARATED BY AT LEAST 7 1/2" (NEC 310.60)
4. WHEN CROSSING A ROADWAY WITH A TRENCH, THE TOP OF THE PVC PIPE MUST BE AT LEAST 24" FROM THE ROAD SURFACE (NEC 300.50)
5. AT ROADWAY CROSSINGS, THE TRENCH SHALL BE BACKFILLED WITH EXISTING MATERIAL AND COMPACTED TO 100% STANDARD PROCTOR IN MINIMUM OF 12 INCH LIFTS, SLURRY IS PREFERRED IN ROAD CROSSINGS AND MAY BE SUBSTITUTED FOR FILL PENDING APPROVAL.
6. TO ALLOW FOR PROPER HEAT DISSIPATION, A 6" PVC CONDUIT IS STANDARDIZED FOR ALL CABLE (NEC 310.60)
7. MULTIMODE FIBER OPTIC 62.5/125 um FOR WIND TOWER GENERATOR SYSTEM
8. BACKFILL WITH APPROVED SAND IF NATIVE EXCAVATED MATERIAL CONTAINS ROCKS OR SHARP DEBRIS
9. TIE WRAP AS REQUIRED TO MAINTAIN BUNDLE CONFIGURATION
10. GROUND WILL BE PLACED WITH CLOSEST ASSOCIATED CIRCUIT ACCORDING TO PROXIMITY IN THE TRENCH PRIOR TO ENTERING CONDUIT
11. RUN A CONTINUOUS RED POLYETHYLENE WARNING TAPE 12" ABOVE EACH CIRCUIT IN THE TRENCH
12. ALL PVC CONDUIT SCHEDULE 40 HDPE
13. THE LAST 1" OF TRENCH SHOULD BE BACKFILLED WITH THE SAME MATERIAL AS EXISTING IN THE ROAD. COMPACT TO 100% STANDARD PROCTOR

14. ANY OPEN-CUT UTILITY INSTALLATION ON ANY COUNTY TRUNK HIGHWAY ROAD SHALL BE COMPLETED AND OPEN TO TRAFFIC IN ANY ONE DAY PERIOD AND NO OPEN-CUT CROSSING SHALL BE LEFT UNCOMPLETED DURING NIGHT TIME OR WEEKENDS
15. ALL EXCAVATED MATERIAL AND SOIL REMOVED FROM THE TRENCH SHALL BE HAULED AWAY AND DISPOSED OF
16. UPON THE START AND THE COMPLETION OF THE PERMITTED WORK, RETURN TO THE PERMIT AUTHORITY: THE WORK START AND WORK COMPLETION NOTICE PROVIDED AT THE TIME OF PERMIT APPROVAL.

REV	DATE	DESCRIPTION	DESIGNED BY	CHECKED BY	APPROVED BY

TYPICAL WIND FARM
TRENCH DIMENSIONS

DWG. NO.
TYP-5004

TYPICAL WIND FARM

E
D
C
B
A

CRANE PAD CROSS SECTION

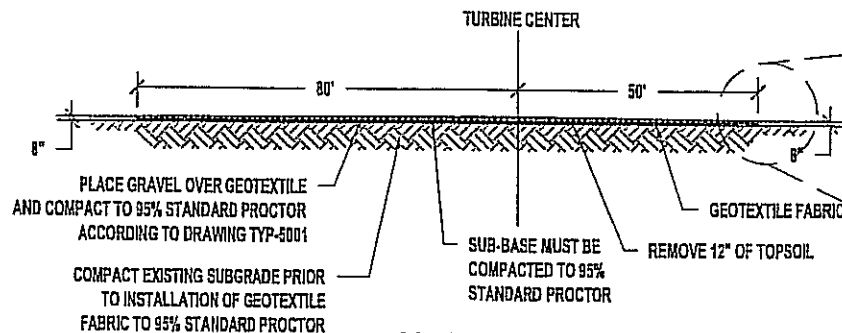

CRANE PAD LAYOUT

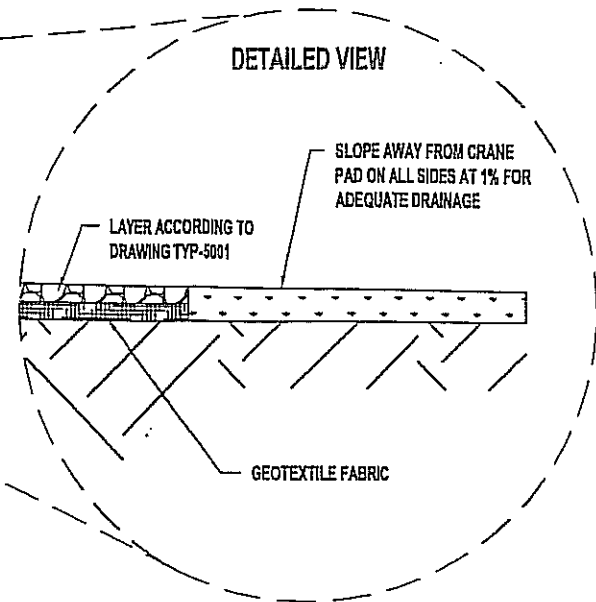
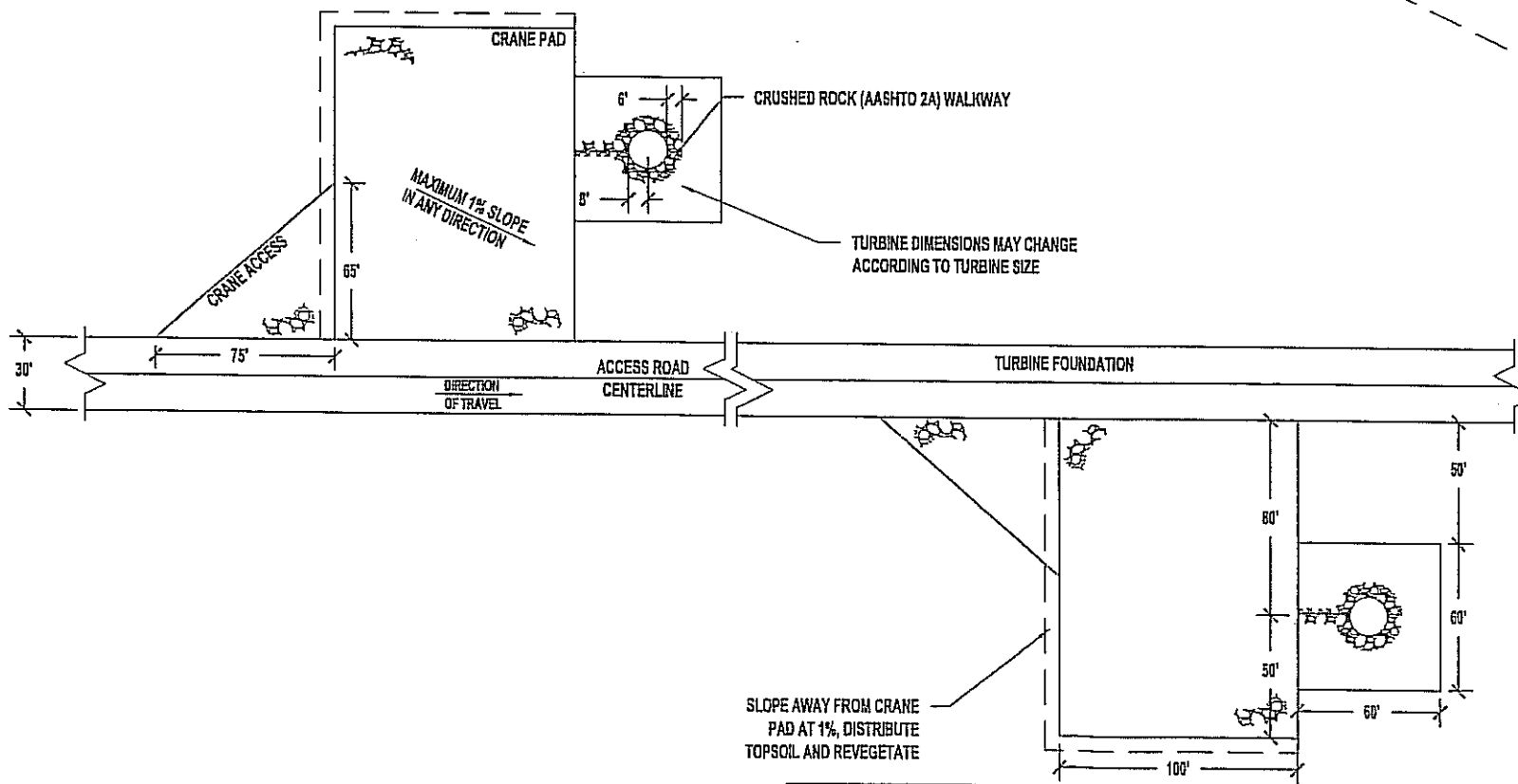

NOTES:

1. CRANE PAD MUST NOT EXCEED A ONE PERCENT (1 %) SLOPE IN ANY DIRECTION.
2. CRANE PAD MAY BE SITUATED ON EITHER THE RIGHT OR LEFT SIDE OF ROAD ACCORDING TO DRAWING SERIES TYP-2000.
3. GRAVEL ON CRANE PADS AND CRANE ACCESS PATHS SHOULD BE LAYERED IN THE SAME MANNER AS THE ACCESS ROADS ACCORDING TO DRAWING TYP-5001.
4. SUB-BASE MUST BE DRY AND COMPACTED TO 95% STANDARD PROCTOR BEFORE PLACING THE GEOTEXTILE FABRIC AND GRAVEL.

TYPICAL WIND FARM
CRANE PAD DIMENSIONS

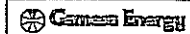

DWG. NO.
TYP-5003

REV	DATE	DESCRIPTION	DESIGNED BY	CHECKED BY	APPROVED BY	SCALE	HTS
3	12/15/11	UPDATED CRANE PAD DIMENSIONS	FA	FA	FA		
2	1/25/11	CHANGES MADE TO CROSS SECTION DIMENSIONS	FA	FA	FA		
1	7/2/10	FIRST ISSUE	FA	FA	FA		

- IN CONCEPT
- PRELIMINARY
- FOR SURVEYING
- FOR CONSTRUCTION
- AS BUILT

± ± TYPICAL WIND FARM

FOUNDATION DESIGN LOADS:

- 1. SERVICE LOADS (UNFACTORED) AS DUTY OF BASE PLATE BASED ON FOUNDATION LOADS PROVIDED BY GAMEA ENGINEER. FOUNDATION LOADS FOR GBT 24M IIA AS 30m HUB HEIGHTS DATED 04/11/2006.
 - 2. 583 KIP, MAX. VERTICAL LOAD DUE TO DEAD LOAD (DPS)
 - 3. 154 KIP, MAX. BASE SHEAR DUE TO WIND LOAD (DPS)
 - 4. 38,544 KIP-FT, MAX. BASE OVERBURDEN MOMENT DUE TO WIND LOAD
- TOWER GAUSSA GBT 24M IIA AS 30m HH

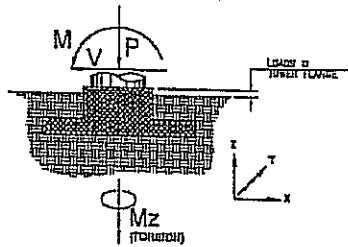

ESTIMATED MATERIAL QUANTITIES

- 1. BASE CONCRETE: 141.2 CU. YDS.
- 2. PERIMETER CONCRETE: 18.3 CU. YDS.
- 3. LEAN CONCRETE: 18.3 CU. YDS.
- 4. REINFORCING STEEL: 8800 LBS.

GENERAL NOTES:

- 1. THIS FOUNDATION IS TO BE USED ONLY FOR NET ALLOWABLE STRESS PRESSURES OF 4000 PSF OR GREATER.
- 2. DIMENSIONS AND QUANTITIES FOR EMBEDMENT RING AND ANCHOR BOLTS BASED ON GAMEA DESIGN 1-PLANE DISASSEMBLY 101 (144) REVISION 1 DATED 3/19/05.
- 3. DESIGN CHECK FOR 2005.

EMBEDMENT RING:

- 1. RING THICKNESS 1.5 IN. (21.0mm) MATERIAL ASTM A311.
- 2. BOLT HOLES EQUALLY SPACED ON OUTER AND INNER BOLT CIRCLE DIAMETERS.

ANCHOR BOLTS & APPURTENANCES:

- 1. WATERTIGHT ANCHOR BOLT GRADE 150 WILLIAMS ALL-THREAD OR EQUAL.
- 2. 1 3/8" x 8'-4" LONG.
- 3. WARDERED WASHERS - ASTM F436.
- 4. SUPPLY W/ HEAVY HEX NUTS.
- 5. POST TENSION BOLTS TO BE 3/4" DIA.
- 6. BOLTS TO BE ENCASED IN PVC PIPE SLEEVES (BOND BREAKER).

GEOTECHNICAL REPORT:

- 1. GEOTECHNICAL FOUNDATION FOR THIS FOUNDATION IS BASED ON "GEOTECHNICAL SURFACE SOIL INVESTIGATION REPORT FOR ALLEGHENY RIDGE WIND FARM FROM GEOTECHNICAL, INC. FROM JOHNSTOWN, PA."

SUBGRADE CAPACITY VERIFICATION:

- 1. GEOTECHNICAL ENGINEER SHALL VERIFY THAT THE SOIL UNDER EACH FOUNDATION HAS THE REQUIRED BEARING CAPACITY. GEOTECHNICAL ENGINEER SHALL RECOMMEND ANY CORRECTIVES REQUIRED.

SUBGRADE PREPARATION:

- 1. PREPARE SUBGRADE IN ACCORDANCE WITH GEOTECHNICAL REPORT RECOMMENDATIONS.

BACKFILL MATERIAL:

- 1. BACKFILL MATERIAL OVER FOUNDATION SHALL BE TO THE DIMENSIONS ON THIS DRAWING AND SHALL HAVE A MINIMUM SOE. DENSITY OF 110 PCF.

COMPRESSIVE STRENGTH:

- 1. PERIMETER 28 DAYS: 5000 PSI
- 2. BASE 28 DAYS: 5000 PSI
- 3. BEFORE PRETENSION OF ANCHOR BOLTS: 5000 PSI
- 4. LEAN CONCRETE (AND SLAB): 5000 PSI
- 5. PRAPARE TROWELED EDGE ON EXPOSED ENDS.

MATERIALS:

- 1. CEMENT: ASTM C150, TYPE I OR TYPE II. MAY BE USED AT CONTRACTOR'S DISCRETION.
 - 2. FLYASH: ASTM C618, CLASS F OR CLASS C. OBTAIN FROM APPROVED GOVERNMENT SOURCE.
 - 3. W/C: 0.4-0.45 (SUBJECT TO APPROVAL)
 - 4. AGGREGATE: ASTM C33, SIZE #7 OR #7.
 - 5. ADULTERES: ASTM C494, SULFATE FREE. ADULTERES ONLY ASTM C494 TYPE A THROUGH E.
 - 6. AIR ENTRAINMENT: ENCS 153 (AN ENTRAINED CONCRETE TO BE USED FOR ALL CONCRETE)
 - 7. MAXIMUM SLUMP: 5 INCH
 - 8. CURT: NON-FERROUS, NON-SWELLING DEFENSER. RAPID SETTING ABOUT 747 OR EQUAL.
- MINIMUM COMPRESSIVE STRENGTH REQUIRED:
3 DAY - 1000 PSI
28 DAY - 11000 PSI
- 9. CURING AGENT: ASTM C493, TYPE 2 (WHITE PORTLAND CEMENT COMPOUND)
 - 10. REINFORCEMENT: ASTM A615, GRADE 60

DETAILING:

- 1. CONCRETE DETAILING SHALL BE IN ACCORDANCE WITH THE LATEST EDITION OF ACI 318.
- 2. SPACING OF REINFORCEMENT MAY BE ADJUSTED TO ACCOMMODATE CORNER RESTRAINT AND OTHER PENETRATIONS THROUGH FOUNDATION. OVER A 3'-0" SPAN, THE TOTAL NUMBER OF REINFORCING BARS SHALL BE PROVIDED AS SHOWN ON THIS SHEET AND ON SHEET S-1.
- 3. CONTRACTOR SHALL SUBMIT SHOP DRAWINGS OF FINAL REINFORCING LAYOUT FOR ENGINEER APPROVAL PRIOR TO PLACEMENT.

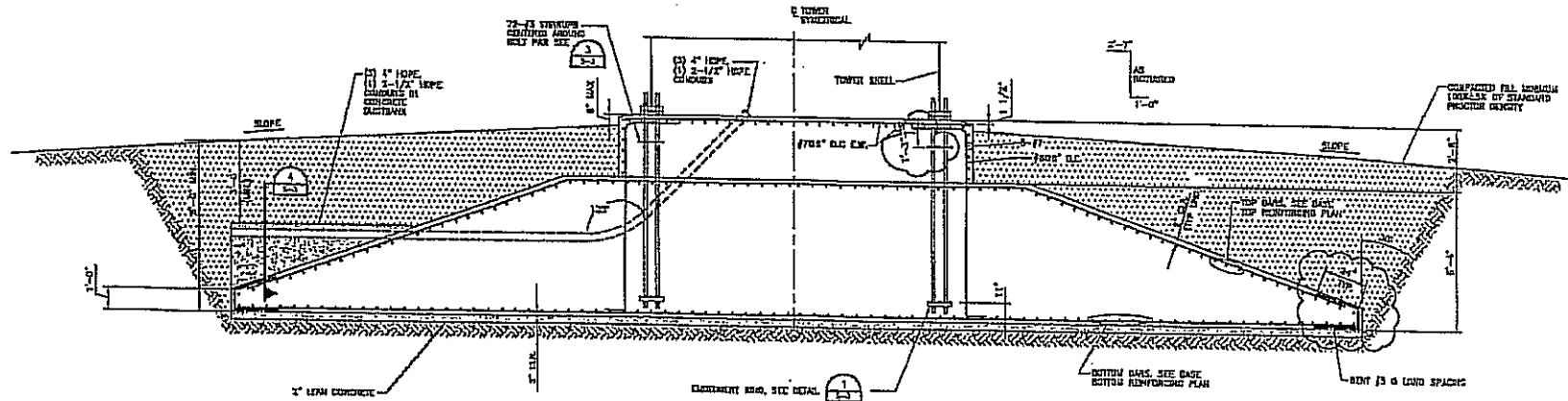

TOWER FOUNDATION SECTION

SAMPLE



DATE	DATE	DESCRIPTION
1	6/2/08	FOR CONSTRUCTION
-	5/17/08	REVISED PRELIMINARY FOR NEW POST TENSION
-	3/12/08	REVISED PRELIMINARY
2	01/11/08	FOR ESTIMATION
-	11/2/07	PRELIMINARY

PROJECT NUMBER: 01 SP	DESIGNED BY: L. SP
CHECKED BY: L. PANE	
DRAWN BY: E. LEINE	
PROJECT NUMBER: 0130	

GAMESA ALLEGHENY RIDGE WIND FARM
CAMBRIA COUNTY, PENNSYLVANIA

GAMESA GBT 24M IIA 30m HH WIND TURBINE FOUNDATION SECTION SHEET
4000 PSF NET ALLOWABLE SOIL

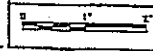

FILENAME: 0805-02100
SCALE: AS NOTED

SHEET S-2

c:\pwworking\hdm\dwg\080502100\0805-02.dwg, 07/1/2008 2:58:08 PM, lhpaw, 1/2

4-6

CLEARING

CRANE PAD AND BLADE LANE CLEARING

NOTES:

1. CLEARING AREAS ARE TO BE MARKED WITH RESPECT TO THE TURBINE LOCATION.
2. CLEARING AREAS SHALL BE TIMBERED AND CLEARED OF ANY STUMPS OR BRUSH.
3. REFER TO DRAWING TYP-5003 FOR CRANE PAD DIMENSIONS.

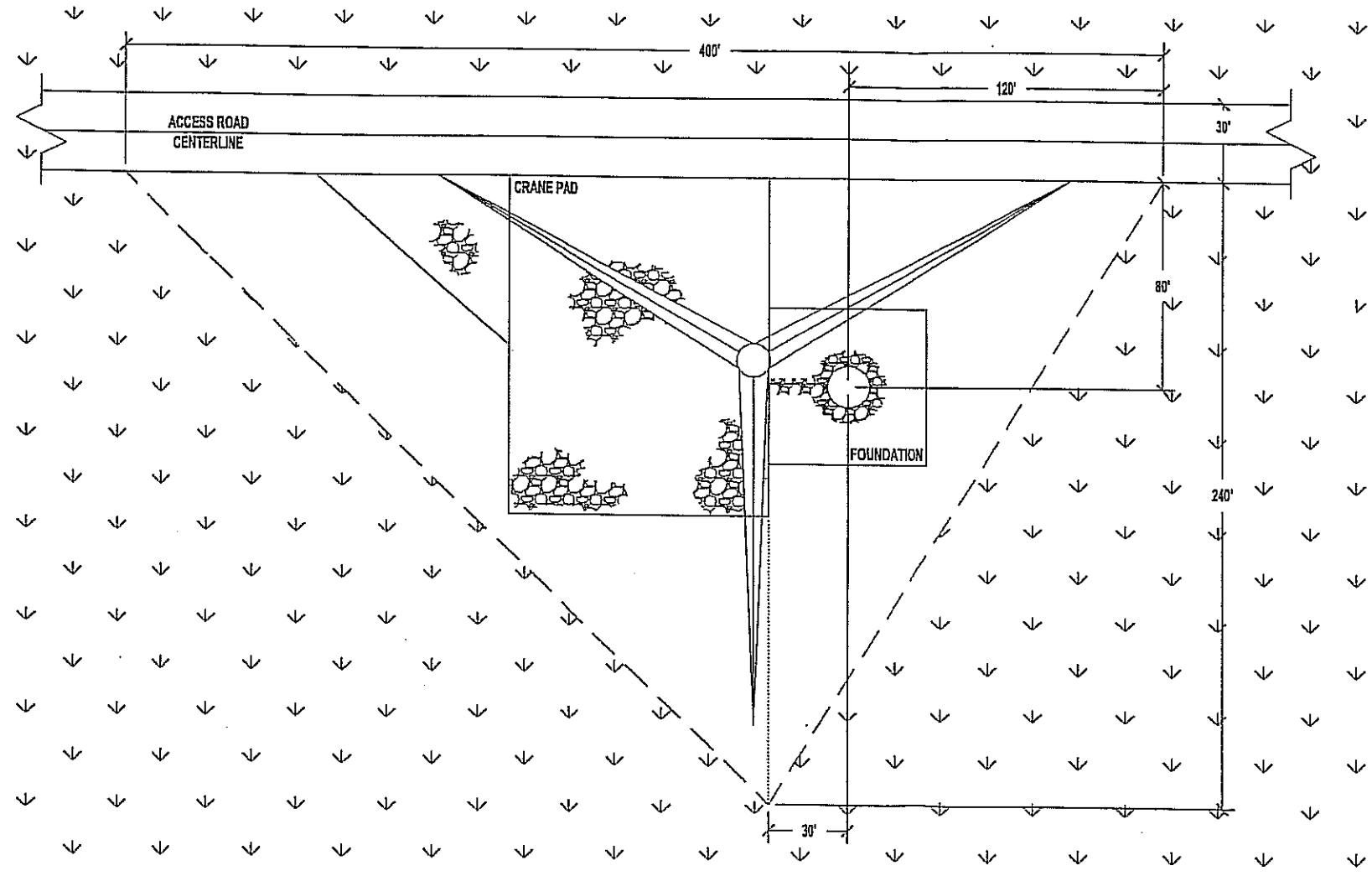

REV	DATE	DESCRIPTION	DESIGNED BY	CHECKED BY	APPROVED BY
1	11/25/08	UPDATED CLEARING DIMENSION FROM 145 TO 130'	WAL	WAL	WAL
2	11/18/08	UPDATED DIMENSION PLACEMENT	WAL	WAL	WAL
3	11/23/08	UPDATED CLEARING DIMENSION	WAL	WAL	WAL
4	1/23/09	FINAL SCALE	WAL	WAL	WAL

IN CONCEPT
 PRELIMINARY
 FOR SUBMITTING
 FOR CONSTRUCTION
 AS BUILT

TYPICAL WIND FARM
CRANE PAD AND BLADE LANE
CLEARING DIMENSIONS

DWG. NO.
TYP-5007

+ + + TYPICAL WIND FARM

SCALE: NOT TO SCALE

E
D
C
B
A

